

IST16

STORAGE INTERFACE FOR TGA-GC/MS COUPLING

Characterisation of the thermal behaviour of materials

Thermogravimetry combined with gas chromatography and mass spectrometry (TGA-GC/MS) is now the method of choice for the qualitative and quantitative analysis of evolved gases.

During the thermal degradation cycle of the materials, the composition of the evolved gas changes too fast for a GC/MS analysis in its standard configuration. With IST16, the chromatographic separation time is no longer a limitation for the detailed study of complex thermal analysis profiles.

The IST16 interface allows to sequentially store in 16 loops several fractions of the gaseous effluent from the TGA and to automatically inject these samples into the GC/MS.

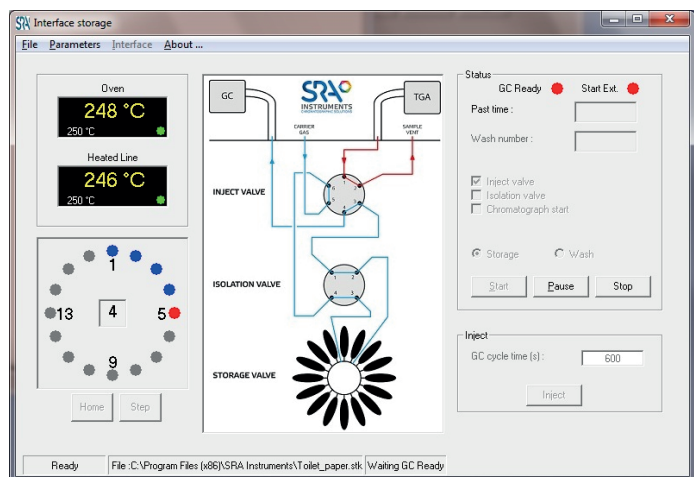

Main page of the software

Software

The IST16 is supplied with a dedicated interface. It is possible to edit the storage sequence, save the methods, view the status of the instrument and automatically manage the start of the GC analyses.



IST16 - Storage interface SRA Instruments

The gases evolved during the cycle of the TGA are transmitted to the storage interface and then to the GC via heated and temperature-controlled micro-volume transfer lines.



With the IST16, it is possible to correlate thermal effects with information concerning the molecular nature, structure and composition of the materials.

The IST16 is designed to be coupled to any TGA and GC/MS models.

IST16
For an efficient
TGA/GC/MS coupling

Application fields :

- Automotive
- Chemical, pharmaceutical
- Research
- Biomass
- Deformation
- Etc.



16 storage loops



High temperature



Multi-systems compatibility



Fully automated

IST16 STORAGE INTERFACE TECHNICAL SPECIFICATIONS

General specifications :

Dimensions (mm) : H 450 ; P 430 ; L 400
Weight : 15 kg

Environmental conditions :

Temperature : 0 °C to 40 °C
Relative humidity : 5 to 95 % non-condensing
Altitude : up to 2000 m max.
Use : indoor or enclosed

Utilities :

Power supply input : 110 or 220 VAC, 1000 W max

Technical specifications :

Number of loops : 16
Loop volume : 250 µL in standard, customised volumes on request
Number of valves : 3 (injection, storage and isolation)
Heated zones : 3, electronically regulated
Valve box temperature : 250 °C
Transfer lines : 2 x 1,2 m
Lines and loops treatment : Sulfinert
Transfer lines temperature : 250 °C

Options :

Installation kit depending on the GC

Installation requirements :

The IST16 interface must be located between TGA and GC. It requires a free space of 60 cm wide between the two instruments.

GC requirement : Split/splitless injector, remote start-in, remote ready-out.

TGA requirement : remote start-out (contact closure)

PC requirement : Windows 7, Ethernet port

Application fields :

Complex analysis of material degradation, polymers deformation, biomass, etc.

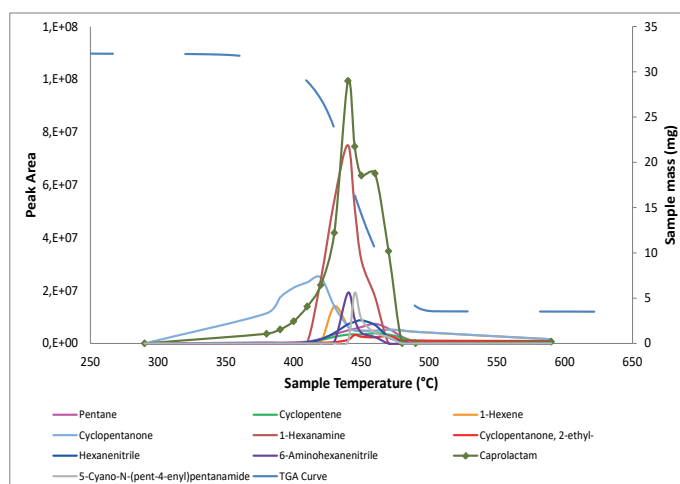

Example of emission profiles obtained with the polyamide 66



Find us on www.srainstruments.com